

MODULATING GAS BURNERS

► MODUBLOC MB SE SERIES

► MB 4 SE	1070/2325 ÷ 4070 kW
► MB 6 SE	1185/3630 ÷ 6000 kW
► MB 8 SE	1175/3300 ÷ 8755 kW
► MB 10 SE	1185/4000 ÷ 9580 kW



The MODUBLOC MB SE series of burners are characterised by a monoblock structure that means all necessary components can be combined in a single unit, making installation easier and faster. The series covers a firing range from 1070 to 9580 kW, and they have been designed for use in hot water boilers or industrial steam generators.

Adjustment is modulating, through an innovative electronic module, which gives control of the air/fuel ratio and PID control of the generator temperature or pressure.

The mechanisms of regulation allow to catch up a high modulation ratio on all firing rates range.

The burner can, therefore, supply with precision the demanded power, guaranteeing a high efficiency system level and the stability setting, obtaining fuel consumption and operating costs reduction.

An exclusive design, with fan unit fitted on line with the combustion head, guarantees low sound emissions, reduced dimensions, easy use and maintenance.

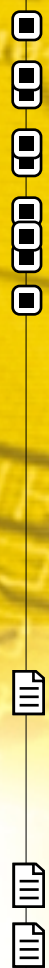

TECHNICAL DATA

Model		▼ MB 4 SE	▼ MB 6 SE	▼ MB 8 SE	▼ MB 10 SE
Burner operation mode		Modulating			
Modulation ratio at max. output		5 ÷ 1			
Servomotor	type	MM 10004 (air) - MM 10005 (gas)			
	run time	s			
Heat output	kW	1070/2325÷4070	1185/3630÷6000	1175/3300÷8755	1185/4000÷9580
	Mcal/h	920/2000÷3500	1019/3122÷5160	1011/2838÷7529	1019/3440÷8239
Working temperature		°C min./max. 0/40			
Net calorific value G20 gas		kWh/Nm ³ 10			
G20 gas density		kg/Nm ³ 0,71			
G20 gas delivery		107/233÷407	119/363÷600	118/330÷876	119/400÷958
Net calorific value G25 gas		kWh/Nm ³ 8,6			
G25 gas density		kg/Nm ³ 0,78			
G25 gas delivery		124/270÷473	138/422÷698	137/384÷1018	138/465÷1114
Net calorific value LPG gas		kWh/Nm ³ 25,8			
LPG gas density		kg/Nm ³ 2,02			
LPG gas delivery		41,5/90÷158	46/141÷233	46/128÷339	46/155÷371
Fan		type Centrifugal with reverse curve blades			
Air temperature		max °C 60			
Electrical supply		Ph/Hz/V 3N/50/400~(±10%) - 3/50/230~(±10%)		3N/50/400~(±10%)	
Auxiliary electrical supply		Ph/Hz/V 1/50/230 ~ (±10%)			
Control box		type LFL 1.333			
Total electrical power		14	16	18	22
Auxiliary electrical power		0,7	0,7	0,7	0,7
Protection level		IP 40			
Motor electrical power		11	13	15	18,4
Rated motor current		38 - 22	46,7 - 27	32	34
Motor start up current		7,3 x I nom	7,6 x I nom	7,6 x I nom	8,1 x I nom
Motor protection level		IP 55			
Ignition transformer		type V1 - V2		230V - 2x5 kV	
		I1 - I2		1,9A - 30mA	
Operation		Intermittent (at least one stop every 24 h) or Continuous as optional (at least one stop every 72 h)			
Sound pressure		82	85	88	
Sound power		--	--	--	--
CO emission		mg/kWh < 15			
NOx emission		mg/kWh < 150			
Directive		90/396 - 89/336 - 73/23 EEC			
Conforming to		EN 676			
Certification		CE 0085AU2367		in progress (CE ...)	

Reference conditions:

Temperature: 20°C

Pressure: 1000 mbar

Altitude: 100 m a.s.l.

Noise measured at a distance of 1 meter.

Since the Company is constantly engaged in the production improvement, the aesthetic and dimensional features, the technical data, the equipment and the accessories can be changed.

This document contains confidential and proprietary information of RIELLO S.p.A. Unless authorised, this information shall not be divulged, nor duplicated in whole or in part.



FIRING RATES

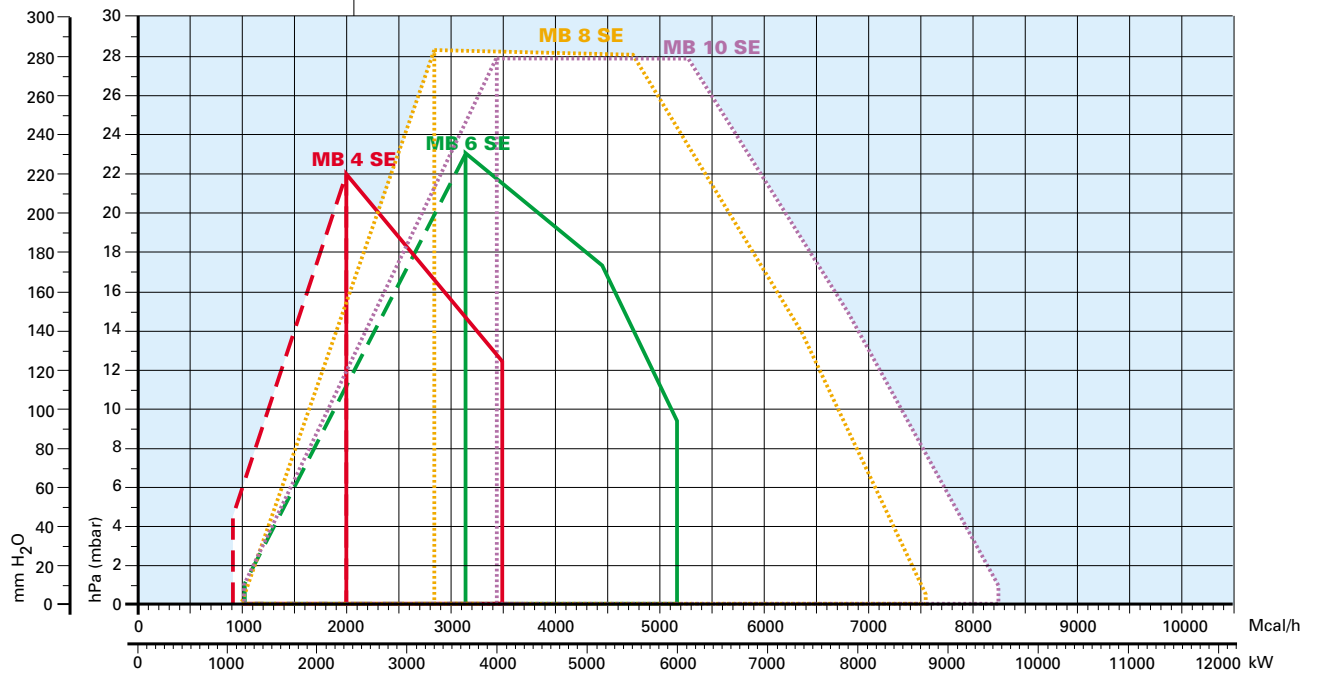

 Useful working field for choosing the burner

 Modulation range

 Firing rate in progress

Test conditions conforming to EN 676:

Temperature: 20°C
 Pressure: 1000 mbar
 Altitude: 100 m a.s.l.



FUEL SUPPLY

► GAS TRAIN

The burners are fitted with a butterfly valve to regulate the fuel, controlled by the main management module of burner through a high precision servomotor.

Fuel can be supplied either from the right or left sides, on the basis of the application requirements. A maximum gas pressure switch stops the burner in case of excess pressure in the fuel line.

The gas train can be selected to best fit system requirements depending on the fuel output and pressure in the supply line.

The gas trains are "Composed" type (assembly of the single components).

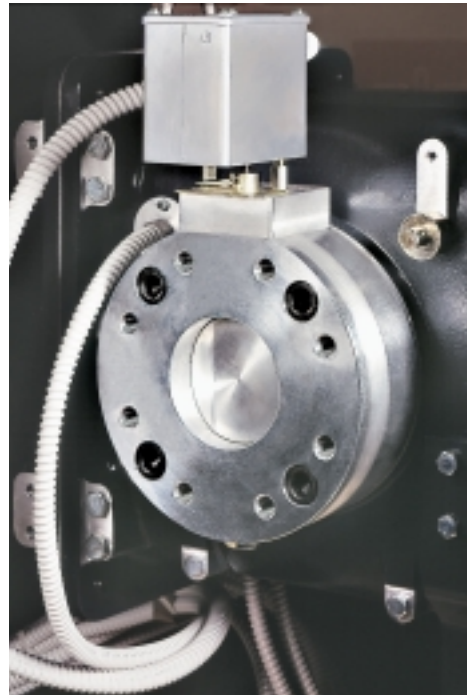

Example of the MB 4 SE gas adjustment butterfly valve

COMPOSED gas train with seal control

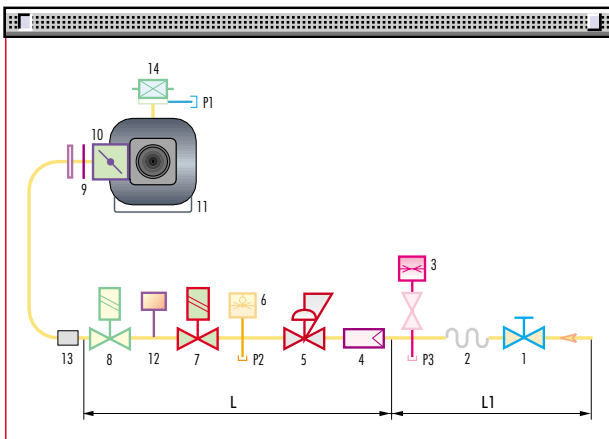

1	Manual valve
2	Anti-vibration joint
3	Pressure gauge with pushbutton cock
4	Filter
5	Pressure regulator (vertical)
6	Minimum gas pressure switch
7	VS safety solenoid (vertical)
8	VR regulation solenoid (vertical) Two settings: - firing output (rapid opening) - maximum output (slow opening)
9	Gasket and flange supplied with the burner
10	Gas adjustment butterfly valve
11	Burner
12	Seal control mechanism for valves 8-9. According to standard EN 676, the seal control is compulsory for burners with maximum output above 1200 kW
13	Gas train-burner adapter
14	Maximum gas pressure switch
P1	Combustion head pressure
P2	Pressure downstream from the regulator
P3	Pressure upstream from the filter
L	Gas train supplied separately, with the code given in the table
L1	Installer's responsibility

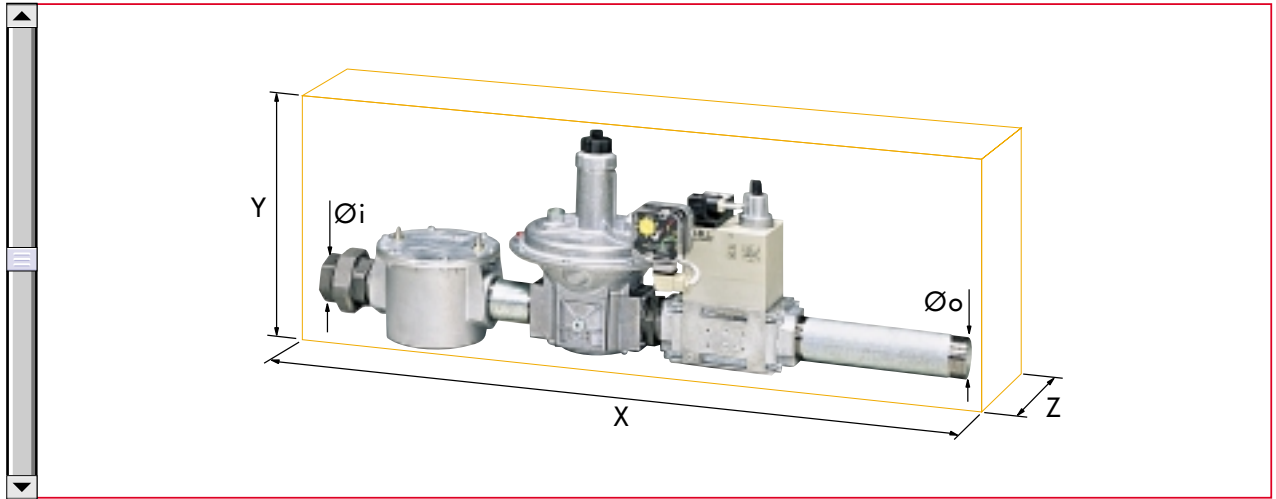

Example of gas train "COMPOSED" type without seal control

Gas trains are approved by standard EN 676 together with the burner.

The overall dimensions of the gas train depends on how they are constructed. The following table shows the maximum dimensions of the gas trains that can be fitted to MB SE burners, intake and outlet diameters and seal control if fitted.

Please note that the seal control can be installed as an accessory, if not already installed on the gas train.

The maximum gas pressure of gas train "Composed" type is 500 mbar.

COMPOSED GAS TRAINS	Name	Code	Ø i	Ø o	X mm	Y mm	Z mm	Seal Control
	CBF 65/1 CT	3970161	DN 65	DN 65	874	356	332	incorporated
	CBF 80/1 CT	3970162	DN 80	DN 80	934	416	332	incorporated
	CBF 100/1 CT	3970163	DN 100	DN 100	1054	501	375	incorporated
	CBF 125/1 CT	3970196	DN 125	DN 125	1166	686	425	incorporated

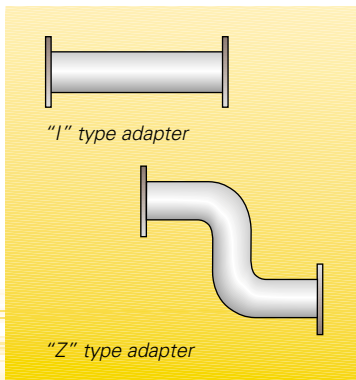

When the diameter of the gas train is different from the set diameter of the burners, an adapter must be fitted between the gas train and the burner.

For further information see paragraph "Accessories".



PRESSURE DROP DIAGRAM

The diagrams indicate the minimum pressure drop of the burners with the various gas trains that can be matched with them; at the value of these pressure drop add the combustion chamber pressure.

The value thus calculated represents the minimum required input pressure to the gas train.

NATURAL GAS

MB 4 SE

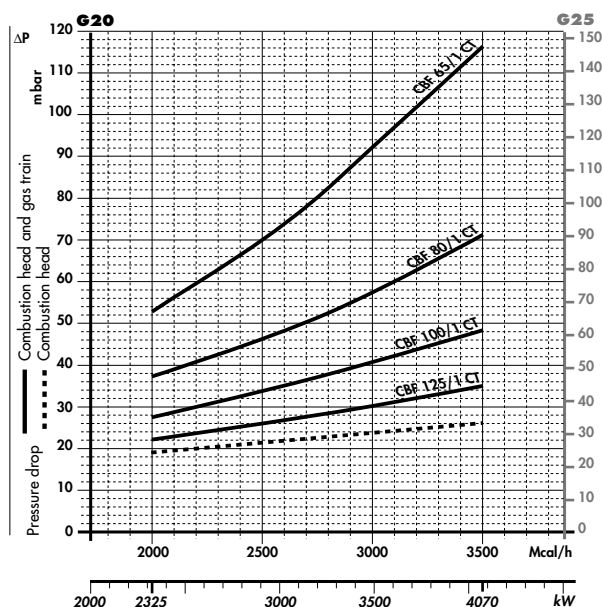

Gas train	Code	Adapter	Seal Control
CBF 65/1 CT	3970161	3010221 (I) 3010225 (Z)	incorporated
CBF 80/1 CT	3970162	3010222 (I) 3010226 (Z)	incorporated

LPG

MB 4 SE

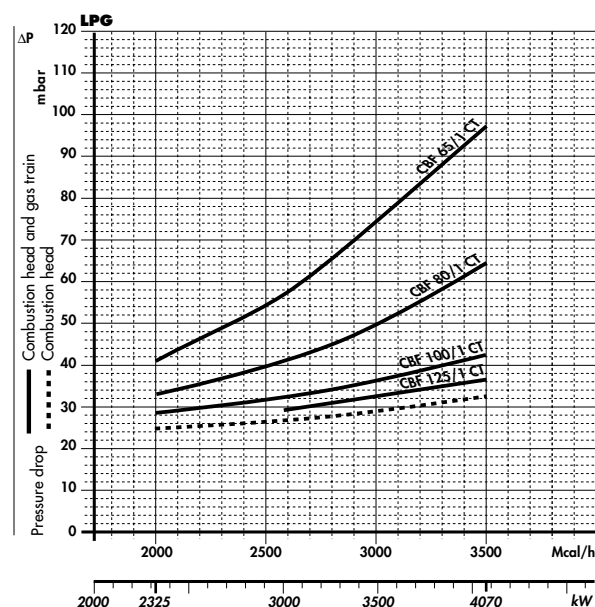

Gas train	Code	Adapter	Seal Control
CBF 100/1 CT	3970163	3010223 (I) 3010227 (Z)	incorporated
CBF 125/1 CT	3970196	3010224 (I) 3010228 (Z)	incorporated

MB 6 SE

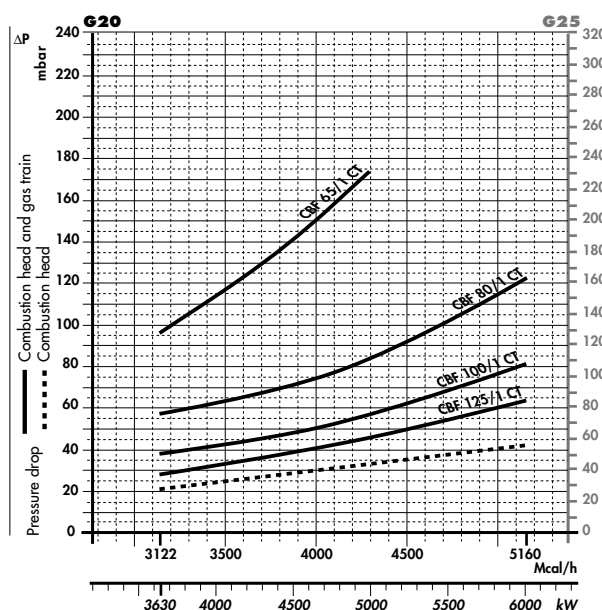

Gas train	Code	Adapter	Seal Control
CBF 65/1 CT	3970161	3010221 (I) 3010225 (Z)	incorporated
CBF 80/1 CT	3970162	3010222 (I) 3010226 (Z)	incorporated

MB 6 SE

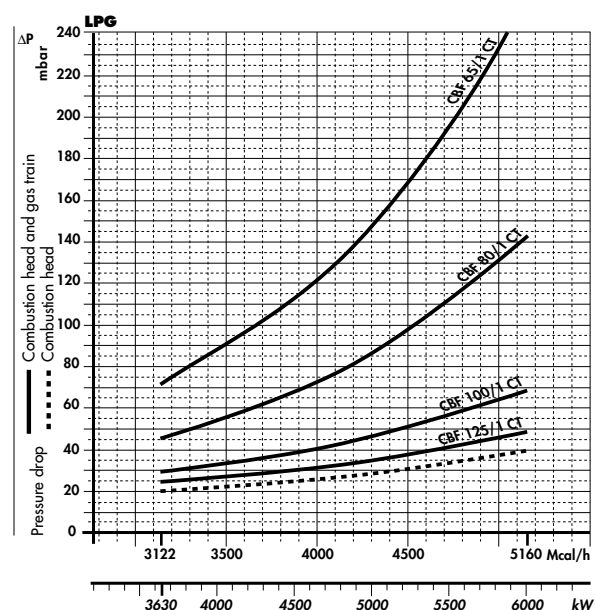

Gas train	Code	Adapter	Seal Control
CBF 100/1 CT	3970163	3010223 (I) 3010227 (Z)	incorporated
CBF 125/1 CT	3970196	3010224 (I) 3010228 (Z)	incorporated



NATURAL GAS

LPG

MB 8 SE

MB 8 SE

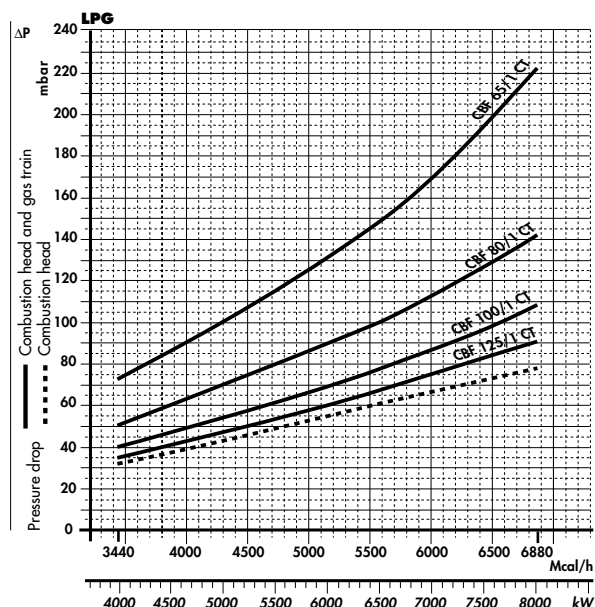
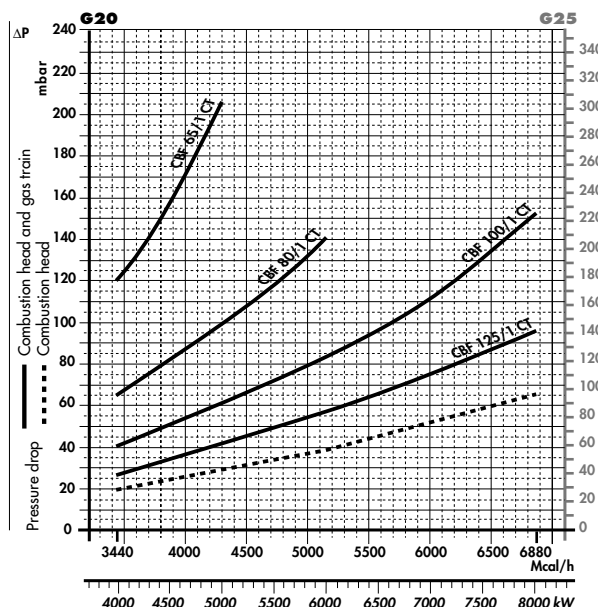

Gas train	Code	Adapter	Seal Control
CBF 65/1 CT	3970161	3010221 (I) 3010225 (Z)	incorporated
CBF 80/1 CT	3970162	3010222 (I) 3010226 (Z)	incorporated

Gas train	Code	Adapter	Seal Control
CBF 100/1 CT	3970163	3010223 (I) 3010227 (Z)	incorporated
CBF 125/1 CT	3970196	3010224 (I) 3010228 (Z)	incorporated

MB 10 SE

MB 10 SE

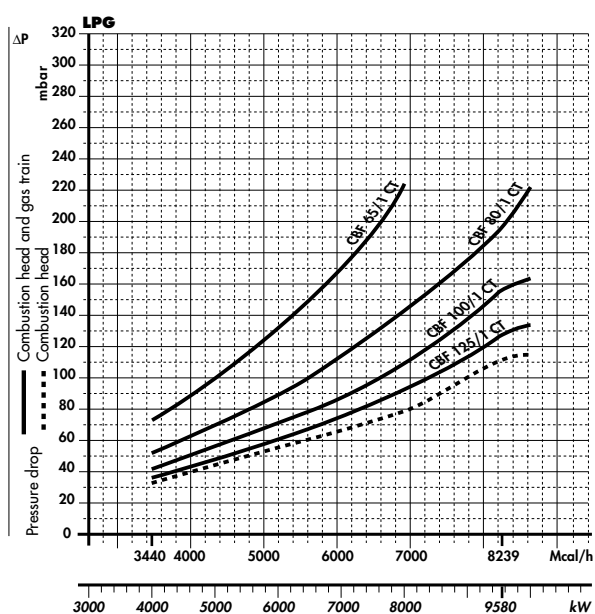
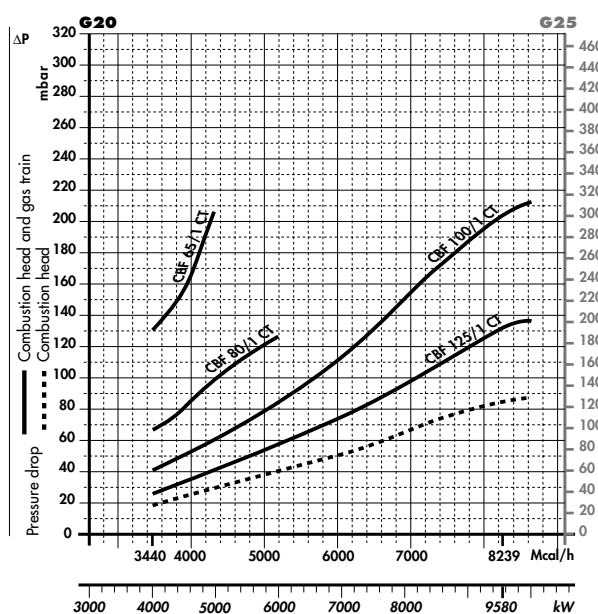

Gas train	Code	Adapter	Seal Control
CBF 65/1 CT	3970161	3010221 (I) 3010225 (Z)	incorporated
CBF 80/1 CT	3970162	3010222 (I) 3010226 (Z)	incorporated

Gas train	Code	Adapter	Seal Control
CBF 100/1 CT	3970163	3010223 (I) 3010227 (Z)	incorporated
CBF 125/1 CT	3970196	3010224 (I) 3010228 (Z)	incorporated



Please contact the Riello Burner Technical Office for different pressure levels from those above indicated and refer to the technical manual for the correct choice of the spring.





SELECTING THE FUEL SUPPLY LINES

The following diagram enables pressure drop in a pre-existing gas line to be calculated and to select the correct gas train.

The diagram can also be used to select a new gas line when fuel output and pipe length are known. The pipe diameter is selected on the basis of the desired pressure drop. The diagram uses methane gas as reference; if another gas is used, conversion coefficient and a simple formula (on the diagram) transform the gas output to a methane equivalent (refer to figure A). Please note that the gas train dimensions must take into account the back pressure of the combustion chamber during operations.

Control of the pressure drop in an existing gas line or selecting a new gas supply line.

The methane output equivalent is determined by the formula fig. A on the diagram and the conversion coefficient.

Once the equivalent output has been determined on the delivery scale (\dot{V}), shown at the top of the diagram, move vertically downwards until you cross the line that represents the pipe diameter; at this point, move horizontally to the left until you meet the line that represents the pipe length.

Once this point is established you can verify, by moving vertically downwards, the pipe pressure drop of on the bottom scale below (mbar).

By subtracting this value from the pressure measured on the gas meter, the correct pressure value will be found for the choice of gas train.

- Example:**
- gas used G25
 - gas output 9.51 mc/h
 - pressure at the gas meter 20 mbar
 - gas line length 15 m
 - conversion coefficient 0.62 (see figure A)

- equivalent methane output $\dot{V} = \left[\frac{9.51}{0.62} \right] = 15.34 \text{ mc/h}$

- once the value of 15.34 has been identified on the output scale (\dot{V}), moving vertically downwards you cross the line that represents 1" 1/4 (the chosen diameter for the piping);
- from this point, move horizontally to the left until you meet the line that represents the length of 15 m of the piping;
- move vertically downwards to determine a value of 1.4 mbar in the pressure drop bottom scale;
- subtract the determined pressure drop from the meter pressure, the correct pressure level will be found for the choice of gas train;
- correct pressure = (20-1.4) = 18.6 mbar

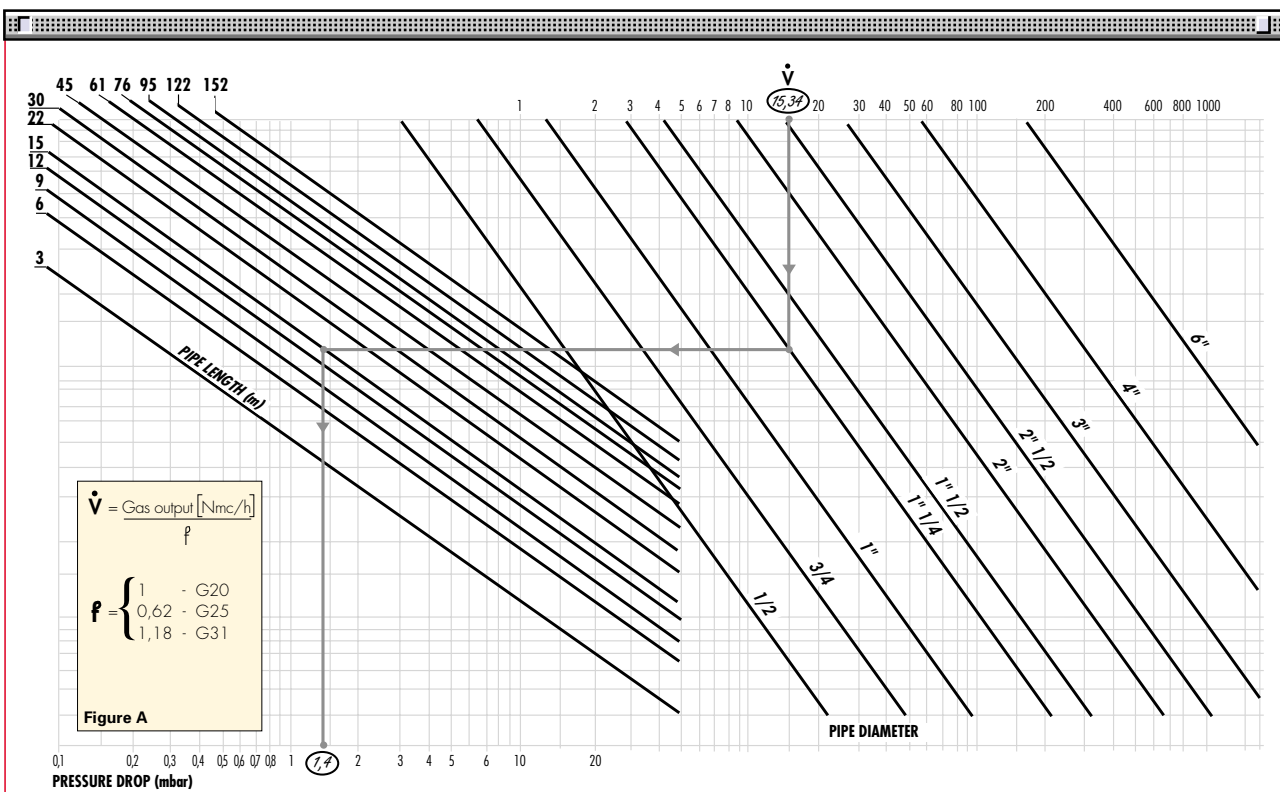

VENTILATION



Example of the servomotor and dampers for air setting

All the burners in the MB series are fitted with fans with reverse curve blades, which give excellent performance and are fitted in line with the combustion head. The air flow and sound-deadening materials that are used in the construction are designed to reduce sound emissions to the minimum and guarantee high levels of performance in terms of output and air pressure.

A high precision servomotor through the main management module installed on each burner of MB series, controls the air dampers position constantly, guaranteeing an optimal fuel-air mix. On request, the

Modubloc burners can be supplied with the "inverter" configuration, which means they are fitted with a device for varying the amount of combustion air through a variable speed action of the fan motor. The addition of the interface inverter module means the burner can work at reduced speed, with further benefits in terms of sound emissions, especially during the night when the perception threshold is lower.



COMBUSTION HEAD



Example of a MODUBLOC MB SE burner combustion head

Simple adjustment of the combustion head allows to adapt internal geometry of the head to the output of the burner. The same adjustment servomotor for the air damper also varies, depending on the required output, the setting of the combustion head, through a simple lever.

This system guarantees excellent mix on all firing rates range.



Flame dimensions

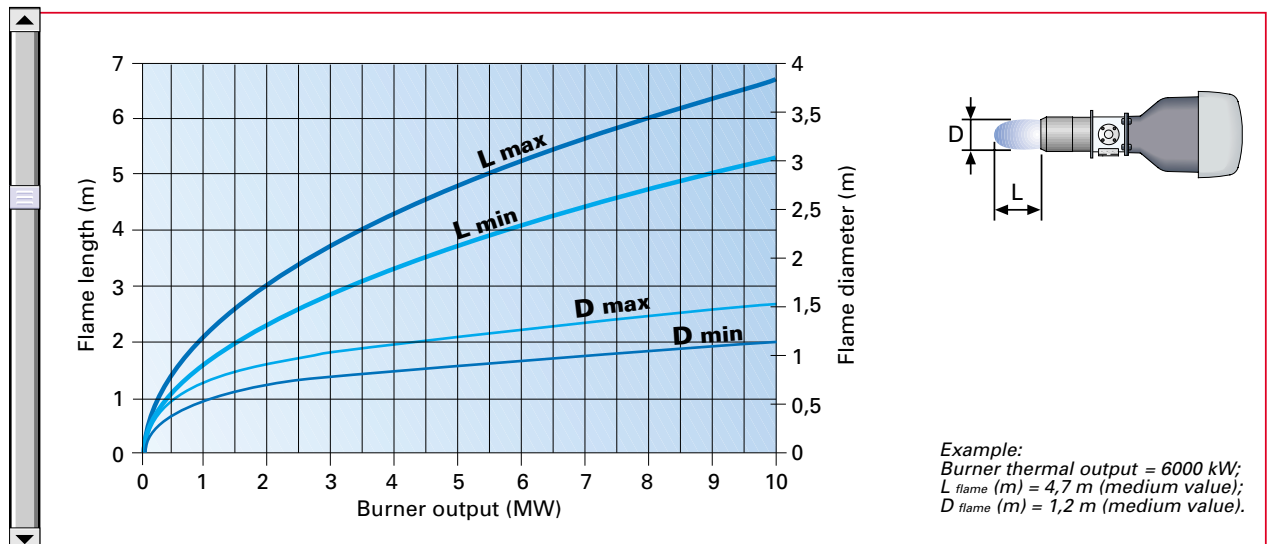



ADJUSTMENT

BURNER OPERATION MODE



Main management module

Each MB series burner has a main electronic microprocessor management panel, which controls both the fuel flow servomotor (with a pressure regulator) and air flow servomotor (with air dampers).

Hysteresis is prevented by the precise control of the two servomotors and the software link. The high precision regulation is due to the absence of mechanical clearance normally found in

mechanical regulation cams on traditional modulating burners.

Inside each MB series burner main electronic microprocessor management panel, there is a PID regulator to control the boiler temperature or pressure. Variables can be controlled by specific accessory probes (see paragraph "Accessories").

The burner can run for a long time on intermediate output settings (see fig. A)

The main electronic management panel shows all operational parameters in real time, so as to keep a constant check on the burner:

- servomotor angle
- required set-point and actual set-point
- fuel consumption (measured indirectly)
- smoke and environmental temperature (with EGA module)
- CO₂, CO, O₂, NO_x e SO₂ value (with EGA module)
- burner stage
- error checking, self diagnostic fault analysis.

The main electronic management panel operations can be increased by installing accessory modules as illustrated below. For available module codes see "Accessories".

Special software can be loaded into a portable PC to input and download data through an interface cable to an infrared device on the front panel of the MB series burner. This is useful both during burner start-up and commissioning phases, and maintenance.

"modulating" operation

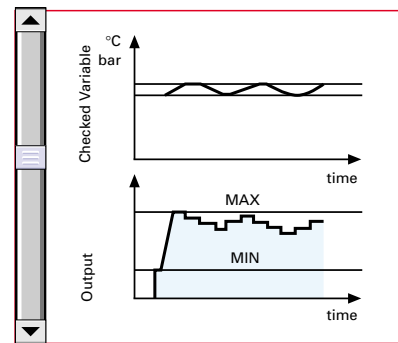

Figure A



D.T.I. module

D.T.I. module (Data Transfer interface)

This electronic module can transfer multiple signals from different local modules to a BMS supervisor software system (Building Management System).

Examples of local modules:

- main management module on each MB series burner which sends and receives signals to indicate or modify the burner working stage
- modules which send and receive signals from the various devices in the boiler room and system.
 - e.g. - analog modules I/O
 - digital modules I/O
 - EGA modules

(For further information see relative paragraph)

Up to ten MB series burners, with or without the EGA module, ten analog modules I/O and ten digital modules I/O can be linked up.

The DTI module uses MODBUS interface protocol as a standard protocol to external supervisory systems (a type of field bus widely used in industrial communication systems).

This type of protocol is used when sample signal rates which need checking are low e.g. for temperature, pressure or pump and fan systems.

With special electronic interface boards other communication protocols (e.g. PROFIBUS) can be used.

DTI module information is transferred directly or by modem to supervisory systems by RS 232 or RS 422 (in the case of long distance up to 1 km) connections.

The supervisory system can also manage a series of MB burners installed in the same system; each main electronic management panel comes with the software needed to manage such a series of burners.



Digital I/O module

Digital I/O module

Digital modules I/O transfer in-coming and out-going information such as working stages and alarms, from the boiler room or from the system in general where one or more MB series burners are installed to a remote supervisor system.

Digital modules I/O manage both input and output signals, e.g.:

- n. 16 input signals (free contacts – max. current 1 A)
- n. 8 output signals (free contacts – max. current 1 A)

The out-going signals can control any device in the boiler room, e.g. pumps, fans, etc...

The in-coming signals can check any device in the boiler room, e.g. pumps, fans, etc... and receive warning signals such as over heating, excess pressure.

Up to ten I/O digital modules can be linked together. Fig. C shows an example of sequencing I/O digital modules linked to a remote supervisor system by a DTI interface.



Analogic I/O module

Analog I/O module

I/O Analog modules transfer in-coming and out-going information about burner working stages and other devices in the boiler room or in the system in general where one or more MB series burners are installed to a remote supervisor system.

I/O Analog modules manage both input and output signals, such as 4-20 mA or 0-10 Volt, e.g.:

- n. 6 input signals
- n. 6 output signals

These modules can be connected to the remote supervisor system in two different ways:

- "LOW LEVEL" connection

each I/O analog module transmits information from a single burner to a remote supervisor system using 4-20 mA or 0-10 Volt signals, e.g.

boiler temperature/pressure, output level, boiler set-point, servomotor angle position, etc. The system becomes operational when each single I/O analog module is programmed by a portable PC and appropriate software.

The set point can be modified by a single in-coming 4-20 mA or 0-10 Volt signal from the supervisor system.

Here is an example of a "LOW LEVEL" connection between I/O analogue modules and remote supervisor system. (figure B)



Figura B - "LOW LEVEL" connection

- "HIGH LEVEL" connection

each I/O analog module transmits in-coming and out-going information about boiler room temperature/pressure, pump rpm, set point, to a remote supervisor system using 4-20 mA or 0-10 Volt signals, through DTI interface.

Up to ten I/O digital modules can be linked together.

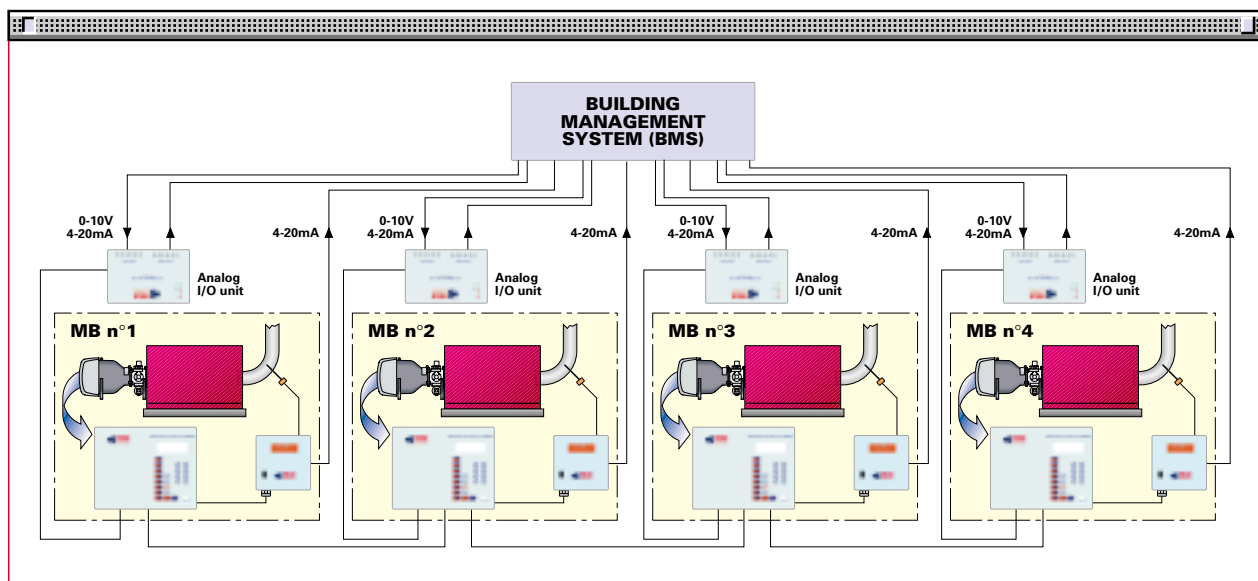
Here is an example of an "HIGH LEVEL" connection between I/O analogue modules and remote supervisor system. (figure C)



Figura C - "HIGH LEVEL" connection



E.G.A. module

E.G.A. module (Exhaust Gas Analyser)

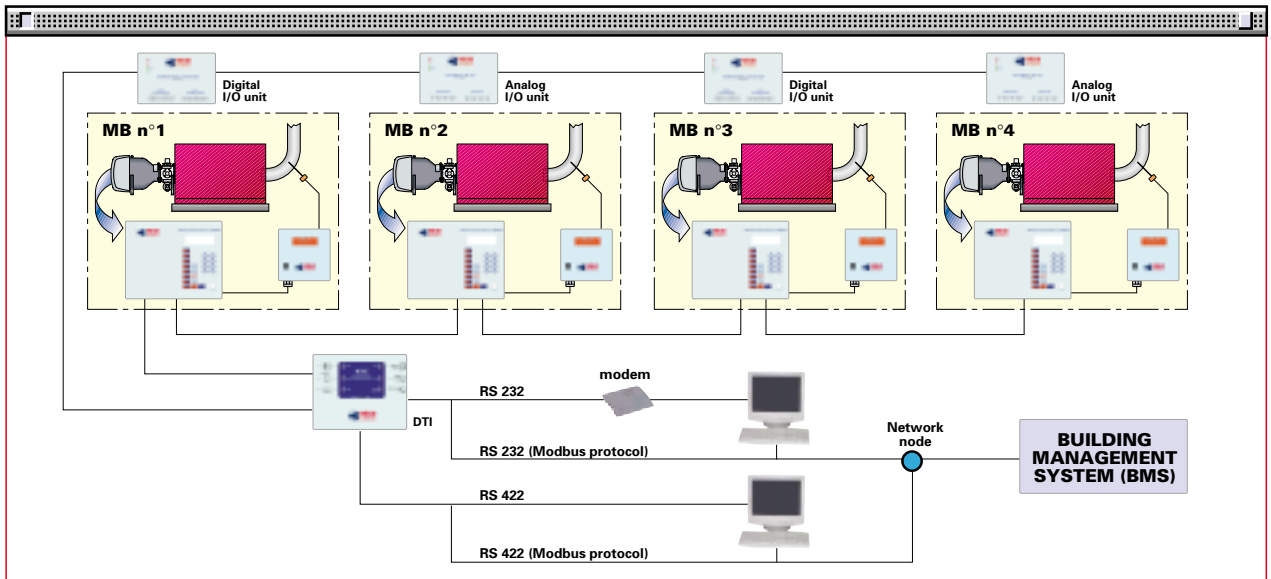
EGA modules measure some of the exhaust gas substances. These modules come with an exhaust gas sampler probe and exhaust gas temperature probe (0-400 °C).

Four different EGA modules are available depending on the type of substance to be checked. (For further information see "accessories" paragraph).

Thanks to EGA module connected to the main electronic microprocessor management panel on each MB series burner, the burner can adjust its working parameters on the basis of continuous combustion gas analysis.

The EGA module creates a closed control link which increases efficiency by up to max 5%.

The following functions are also available:

- smoke and environmental temperature measurement
- viewing of measured parameters on main management display panel
- burner lock-out when some parameters exceed permitted levels (settable)
- combustion optimisation with automatic air damper setting (adjustment O₂ level)
- automatic re-adjustment at each firing

The information from EGA modules can be sent to a remote supervisor system in two ways:

- through six signals (4-20mA) on a terminal board (see layout fig. B)
To activate this operation each single EGA module must be programmed using a PC with appropriate software.
- through the DTI interface module (see layout fig. C)

Connections between Modules

A data cable type BELDEN 9501 or similar, which can be ordered as an accessory (see accessories paragraph), must be used to connect the above modules.

note To develop the various layouts or for further information about single modules please contact the Riello Burners Technical Office.



The following diagram summarises how MB series burners and modules can be used for the supervision of boiler rooms or systems in general.

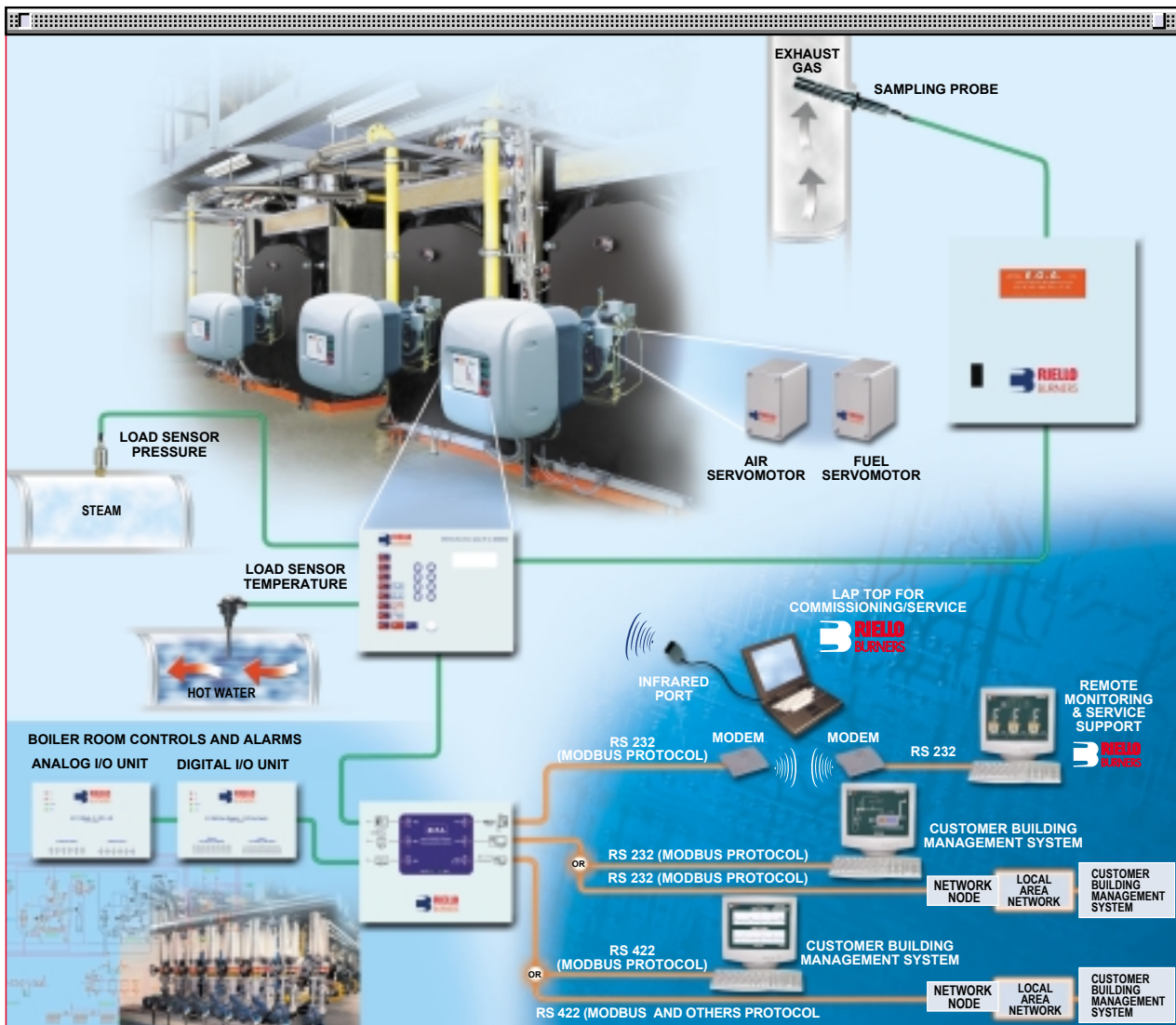

Example of boiler room management system

START UP CYCLE

MB 4-6-8-10 SE

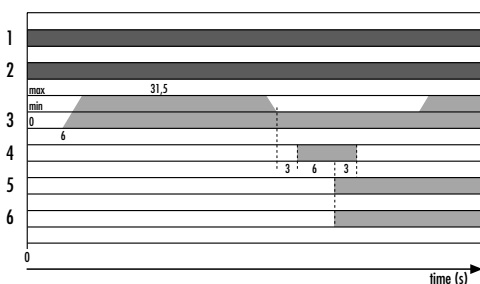

- 1 - Closing thermostat
- 2 - Fan motor working
- 3 - Air damper
- 4 - Ignition transformer
- 5 - Valves open
- 6 - Flame presence

WIRING DIAGRAMS

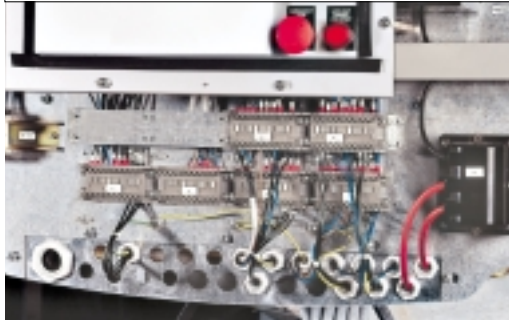

Electrical connections must be made by qualified and skilled personnel, according to the local norms.

Example of the terminal board for electrical connections

▶ THREE PHASE SUPPLY TO THE POWER CIRCUIT AND CONNECTING THE AUXILIARY CONTROLS

MB 4-6-8-10 SE

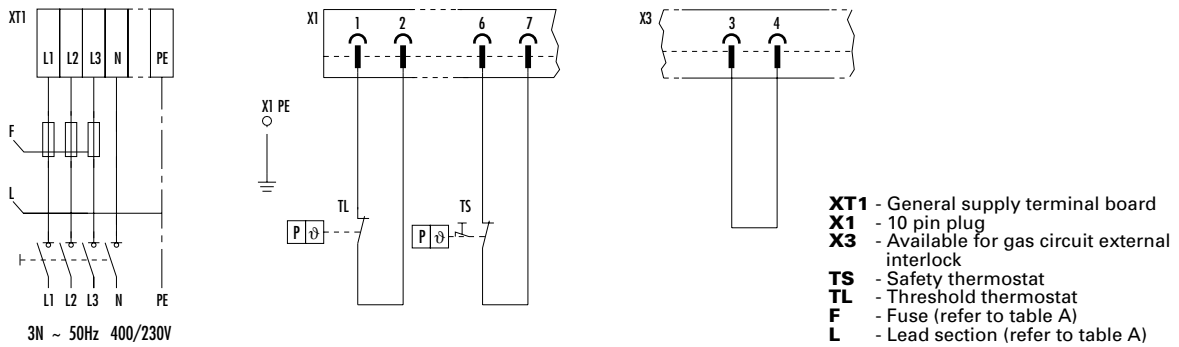

▶ CONNECTION OF THE PROBES FOR THE CONTROLLED PARAMETER AND DATA CONNECTION FOR THE VARIOUS MODULES (Accessories)

MB 4-6-8-10 SE

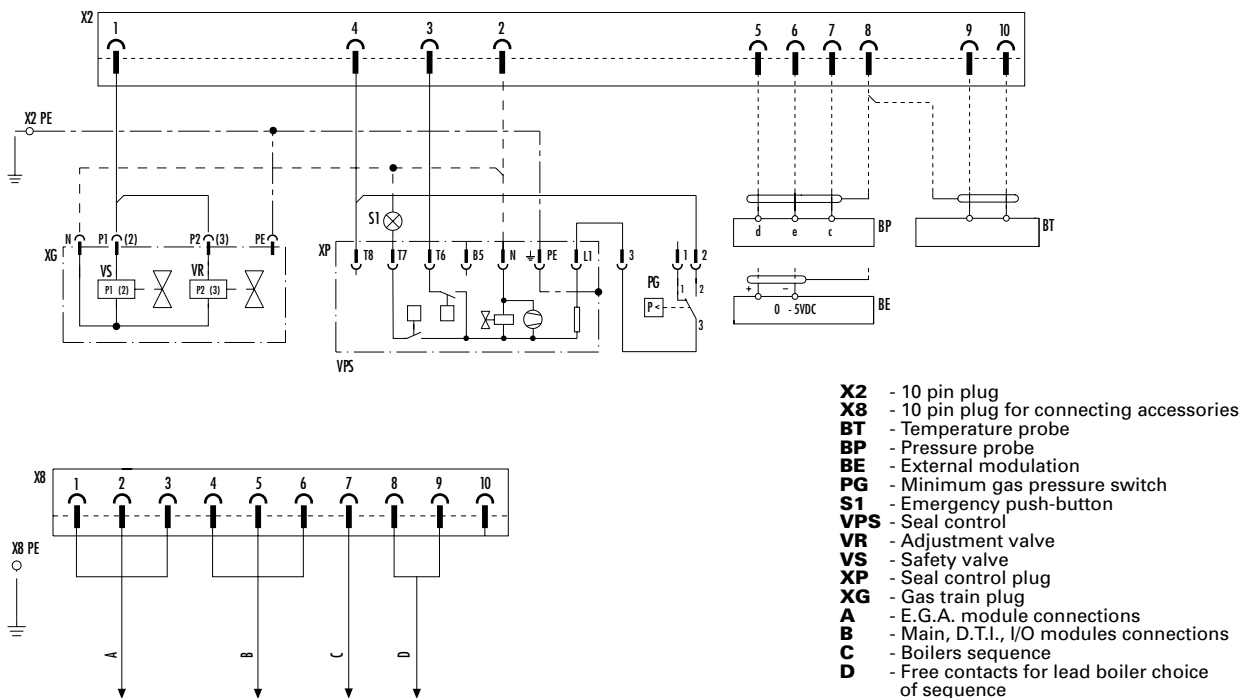

SIGNALS FOR WORKING STATUS OF THE MAIN COMPONENTS

MB 4-6-8-10 SE

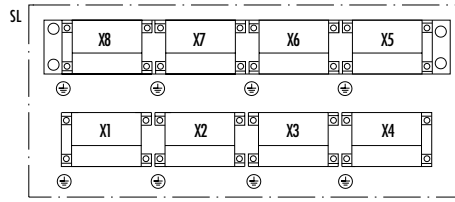
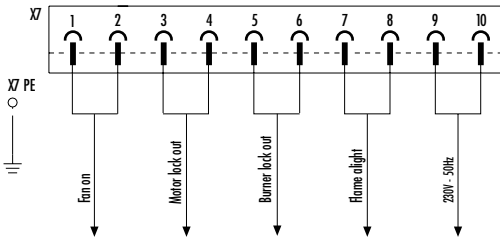

X7 - 10 pin output plug, free contacts

SL - Layout plug diagram

X4, 5, 6 - Plugs for electrical factory-set connections

The following table shows the supply lead sections and the type of fuse to be used.

Model	▼ MB 4 SE		▼ MB 6 SE		▼ MB 8 SE	▼ MB 10 SE
	230V	400V	230V	400V	400V	400V
F A	50A aM	32A aM	50A aM	32A aM	40A aM	50A aM
L mm ²	10	6	10	6	10	10

Table A

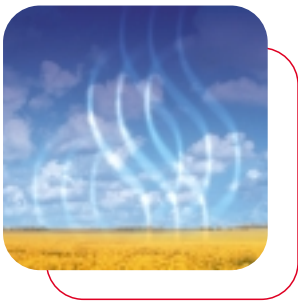

EMISSIONS

NO₂ EMISSIONS

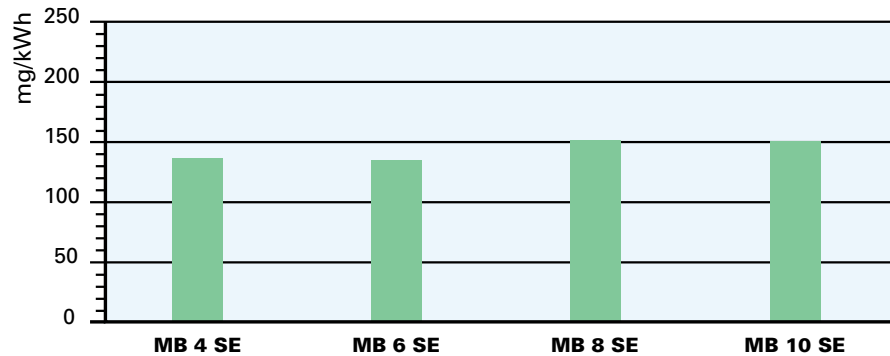

CO EMISSIONS

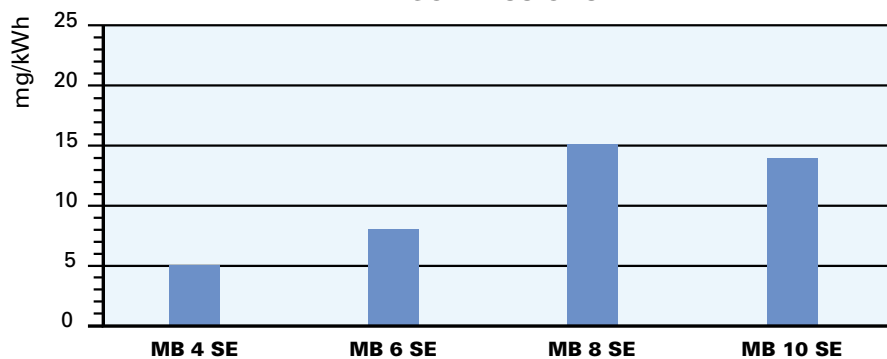

The emission data has been measured in the various models at maximum output, according to EN 676 standard.



SOUND EMISSIONS

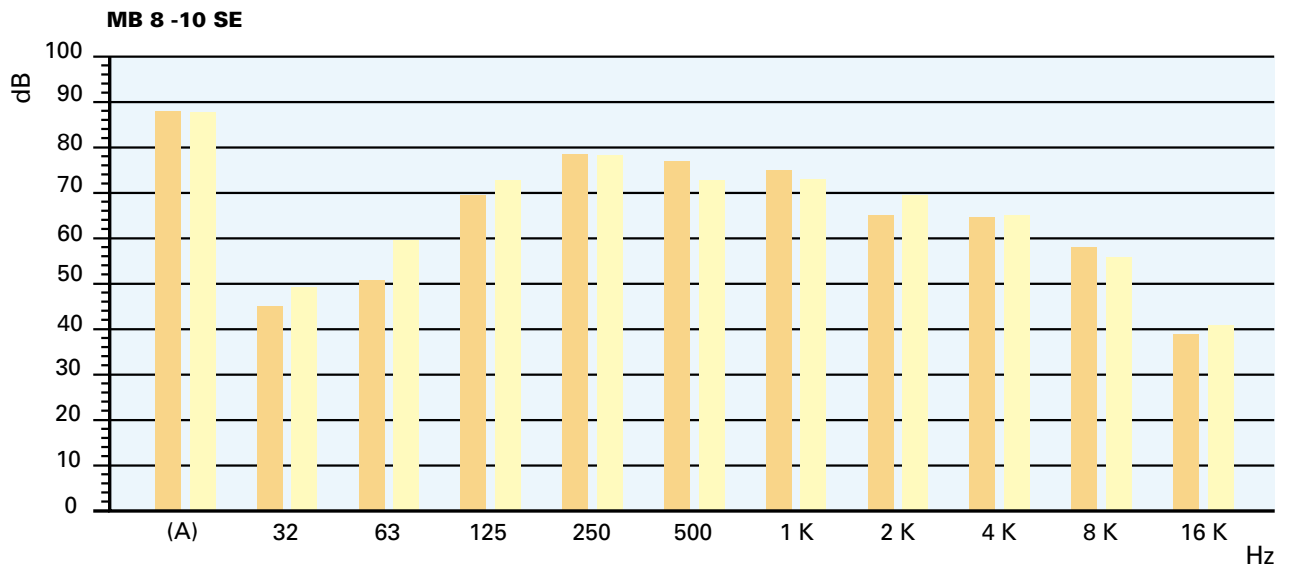
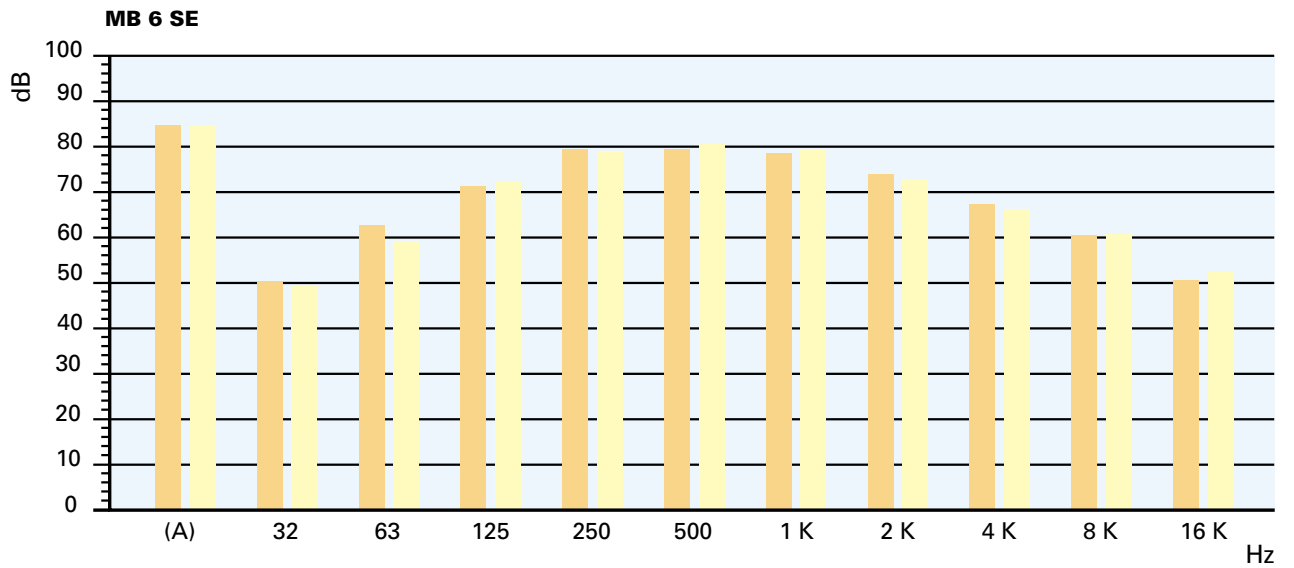
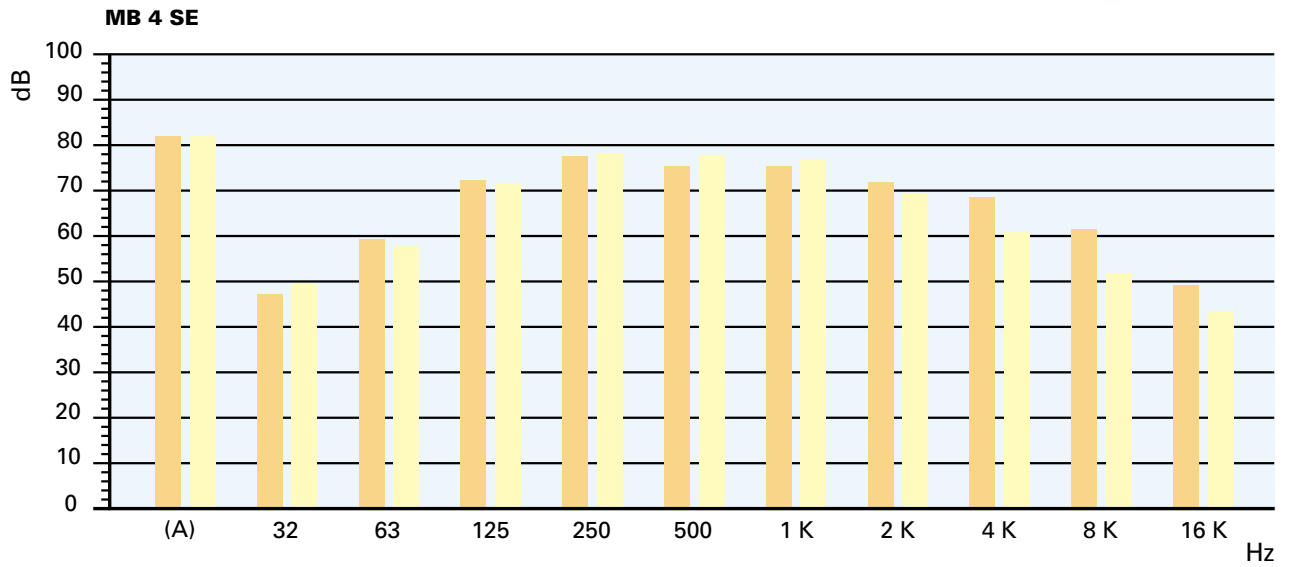

(A) Value obtained in dB(A)

Maximum modulation

Minimal modulation





OVERALL DIMENSIONS (mm)

BURNER

MB 4-6-8-10 SE

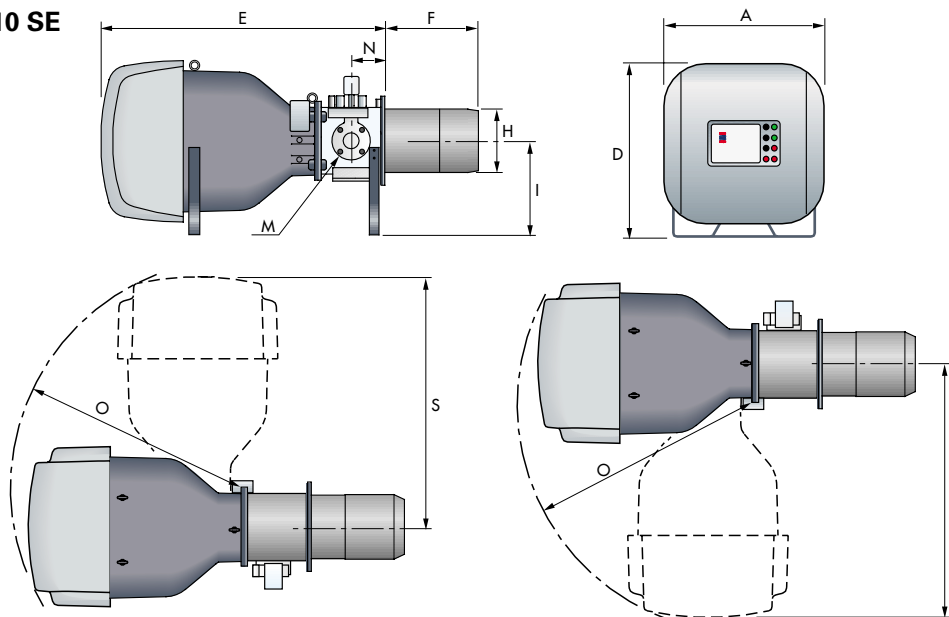

Model	A	D	E	F	H	I	M	N	O	S
▶ MB 4 SE	840	910	1470	511	336	490	DN80	183	1205	1330
▶ MB 6 SE	840	910	1470	511	336	490	DN80	183	1205	1330
▶ MB 8 SE	1007	1079	1900	530	413	575	DN80	208	1570	1740
▶ MB 10 SE	1007	1079	1900	530	413	575	DN80	208	1570	1740

BURNER - BOILER MOUNTING FLANGE

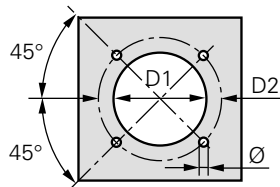

Model	D1	D2	Ø
▶ MB 4 SE	350	496	M20
▶ MB 6 SE	350	496	M20
▶ MB 8 SE	418	608	M20
▶ MB 10 SE	418	608	M20

PACKAGING

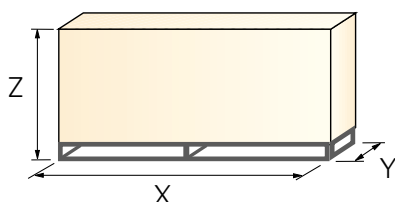

Model	X	Y	Z	kg
▶ MB 4 SE	2120	1005	1175	300
▶ MB 6 SE	2120	1005	1175	300
▶ MB 8 SE	2690	1170	1350	450
▶ MB 10 SE	2690	1170	1350	450

INSTALLATION DESCRIPTION



Installation, start up and maintenance must be carried out by qualified and skilled personnel.

All operations must be performed in accordance with the technical handbook supplied with the burner.



Access to the internal components is very simple, as the back of the burner is hinged which means it can be completely opened.

The burners can be supplied with the opening on the right or left, depending on personal requirements.

BURNER SETTING

- ▶ All the burners have lifting rings, for easier installation and maintenance.
- ▶ After drilling the boilerplate, using the supplied gasket as template, prepare a suitable lifting system and, after hooking onto the rings, fix burner to the boiler.
- ▶ Install the gas train, choosing it on the basis of the maximum boiler output and on the basis of the diagrams enclosed with the burner instructions.
- ▶ Adjust the combustion head run, using the mechanism lever.



ELECTRICAL CONNECTIONS AND START UP

- ▶ Make the electrical connections to the burner following the wiring diagrams included in the instruction handbook.
- ▶ Turning the motor check the led signalling correct rotation direction, at left of the plugs group, is on.
- ▶ Perform a first ignition calibration on the gas train.
- ▶ On start up, check:
 - gas pressure at the combustion head (to max. and min. output)
 - combustion quality, in terms of unburned substances and excess air.





BURNER ACCESSORIES

DTI module (Data Transfer Interface)

This electronic module can transfer multiple signals from different local modules to a BMS supervisor software system (Building Management System).



DTI module	
Burner	module code
MB 4 - 6 - 8 - 10 SE	3010234

I/O digital module

Digital modules I/O transfer in-coming and out-going information such as working stages and alarms, from the boiler room or from the system in general where one or more MB series burners are installed to a remote supervisor system.



I/O digital module	
Burner	module code
MB 4 - 6 - 8 - 10 SE	3010233

I/O analogic module

I/O Analog modules transfer in-coming and out-going information about burner working stages and other devices in the boiler room or in the system in general where one or more MB series burners are installed to a remote supervisor system.

I/O Analog modules manage both input and output signals, such as 4-20 mA or 0-10 Volt.



I/O analogic module	
Burner	module code
MB 4 - 6 - 8 - 10 SE	3010232



EGA module (Exhaust Gas analyser)

EGA modules measure some of the exhaust gas substances. These modules come with an exhaust gas sampler probe and exhaust gas temperature probe (0-400 °C). Four different EGA modules are available depending on the type of substance to be checked, as given in the following table:



EGA module		
Burner	Analysed gas	module code
MB 4 - 6 - 8 - 10 SE	CO, CO ₂ , O ₂	3010235
MB 4 - 6 - 8 - 10 SE	CO, CO ₂ , O ₂ , NO	3010236
MB 4 - 6 - 8 - 10 SE	CO, CO ₂ , O ₂ , SO ₂	3010237
MB 4 - 6 - 8 - 10 SE	CO, CO ₂ , O ₂ , NO, SO ₂	3010238

Belden 9501 type leads

All the connections for the above modules must be done using a BELDEN 9501 type lead, which is available as an accessory in coils of 50 m.

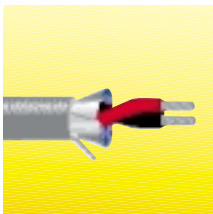

Belden 9501 lead	
Burner	lead code
MB 4 - 6 - 8 - 10 SE	3010239

Accessories for modulating operation

Main management module allows a modulating operation with use of probes chosen on the basis of the application.

The following table lists the accessories for modulating operation, with the application field.



Probe			
Burner	Probe type	Range (°C) (bar)	Probe code
MB 4 - 6 - 8 - 10 SE	Temperature	0 ÷ 400°C	3010187
MB 4 - 6 - 8 - 10 SE	Pressure	0 ÷ 3 bar	3010246
MB 4 - 6 - 8 - 10 SE	Pressure	0 ÷ 18 bar	3010186
MB 4 - 6 - 8 - 10 SE	Pressure	0 ÷ 30 bar	3010188



LPG kit

For burning LPG gas, a special kit is available to be fitted to the combustion head of the burner, as given in the following table:

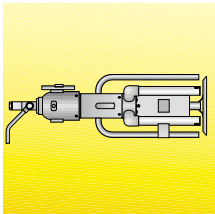

LPG kit	
Burner	Kit code
MB 4 SE	3010189
MB 6 SE	3010190
MB 8 SE	in progress
MB 10 SE	3010296

Burner support

For easier maintenance, a mobile burner support has been designed, which means the burner can be dismantled without the need for forklift trucks.



Burner support	
Burner	Support code
MB 4 - 6 SE	in progress
MB 8 - 10 SE	in progress

GAS TRAIN ACCESSORIES

Adapters

In certain cases, an adapter must be fitted between the gas train and the burner, when the diameter of the gas train is different from the set diameter of the burner.

Below are given the adapters than can be fitted on the various burners:

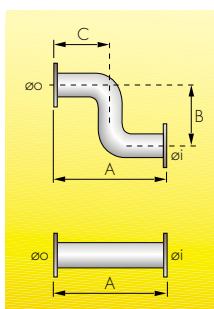

Adapters								
Burner	Gas train	Adapter type	Dimensions					Adapter code
			Øi DN	Øo DN	A mm	B mm	C mm	
MB 4-6-8-10 SE	CBF 65/1 CT	I	65	80	320	--	--	3010221
MB 4-6-8-10 SE	CBF 80/1 CT	I	80	80	320	--	--	3010222
MB 4-6-8-10 SE	CBF 100/1 CT	I	100	80	320	--	--	3010223
MB 4-6-8-10 SE	CBF 125/1 CT	I	125	80	320	--	--	3010224
MB 4-6-8-10 SE	CBF 65/1 CT	Z	65	80	400	480	225	3010225
MB 4-6-8-10 SE	CBF 80/1 CT	Z	80	80	400	480	225	3010226
MB 4-6-8-10 SE	CBF 100/1 CT	Z	100	80	400	480	225	3010227
MB 4-6-8-10 SE	CBF 125/1 CT	Z	125	80	500	480	300	3010228

Stabiliser spring

To vary the pressure range of the gas train stabilisers, accessory springs are available. The following table shows these accessories with their application range:

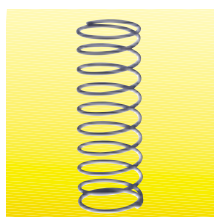

Stabiliser spring		
Gas train	Spring	Spring code
CBF 65/1 CT - 80/1 CT	Red from 25 to 55 mbar	3010133
CBF 100/1 CT	Red from 25 to 55 mbar	3010134
CBF 125/1 CT	Red from 25 to 55 mbar	3010315
CBF 125/1 CT	Yellow from 30 to 70 mbar	3010316
CBF 65/1 CT - 80/1 CT	Black from 60 to 110 mbar	3010135
CBF 100/1 CT	Black from 60 to 110 mbar	3010136
CBF 125/1 CT	Black from 60 to 110 mbar	3010317
CBF 65/1 CT - 80/1 CT	Pink from 90 to 150 mbar	3090456
CBF 100/1 CT	Pink from 90 to 150 mbar	3090489
CBF 125/1 CT	Pink from 90 to 150 mbar	3010318

Please refer to the technical manual for the correct choice of spring.



SPECIFICATION

A specific index guides your choice of burner from the various models available in the MODUBLOC MB series. Below is a clear and detailed specification description of the product.

DESIGNATION OF SERIES

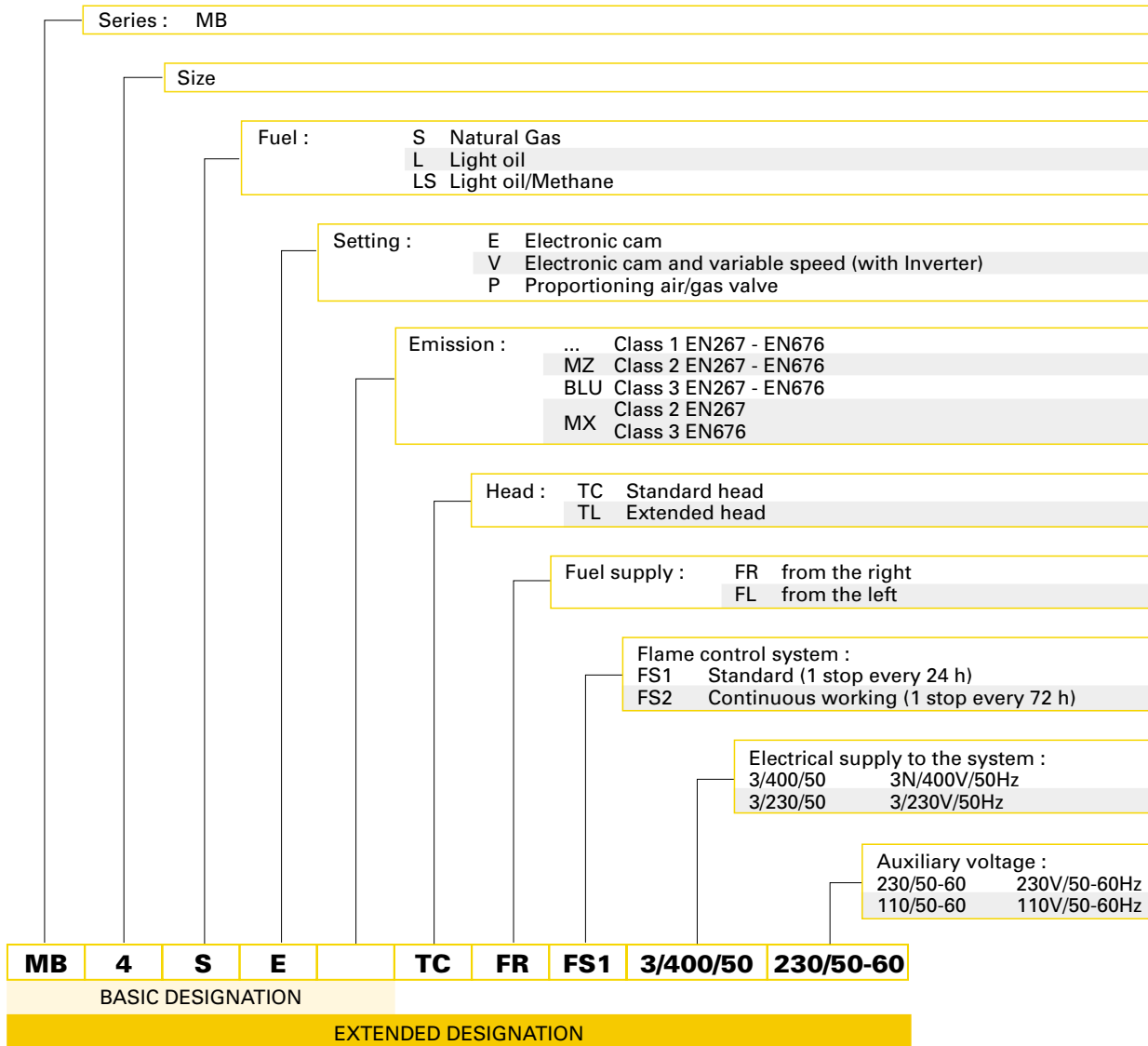

AVAILABLE BURNER MODELS

MB4SE	TC	FR	FS1	3/400/50	230/50-60	MB8SE	TC	FR	FS1	3/400/50	230/50-60
MB4SE	TC	FR	FS1	3/230/50	230/50-60	MB8SE	TC	FR	FS2	3/400/50	230/50-60
MB4SE	TC	FL	FS1	3/400/50	230/50-60	MB8SE	TC	FL	FS1	3/400/50	230/50-60
MB4SE	TC	FL	FS1	3/230/50	230/50-60	MB8SE	TC	FL	FS2	3/400/50	230/50-60
MB6SE	TC	FR	FS1	3/400/50	230/50-60	MB10SE	TC	FR	FS1	3/400/50	230/50-60
MB6SE	TC	FR	FS1	3/230/50	230/50-60	MB10SE	TC	FR	FS2	3/400/50	230/50-60
MB6SE	TC	FL	FS1	3/400/50	230/50-60	MB10SE	TC	FL	FS1	3/400/50	230/50-60
MB6SE	TC	FL	FS1	3/230/50	230/50-60	MB10SE	TC	FL	FS2	3/400/50	230/50-60

Other versions are available on request.



▶ PRODUCT SPECIFICATION

Burner

Monoblock forced draught gas burner with modulating operation, fully automatic, made up of:

- Fan with reverse curve blades high performance with low sound emissions
- Air suction circuit lined with sound-proofing material
- Air damper for air setting controlled by a high precision servomotor
- Air pressure switch
- Fan starting motor at 2900 rpm, three-phase 230/400 - 400/690 V with neutral, 50Hz
- Mobile combustion head, that can be set on the basis of required output, fitted with:
 - stainless steel end cone, resistant to corrosion and high temperatures
 - ignition electrodes
 - flame stability disk
- Automatic regulator for gas delivery, controlled by a high precision servomotor
- Maximum gas pressure switch, with pressure test point, for halting the burner in the case of over pressure on the fuel supply line
- Module for air/fuel setting and output modulation with incorporated PID control of temperature or pressure of the heat generator
- Flame control panel for controlling the system safety
- Photocell for flame detection
- Star/triangle starter for the fan motor
- Main electrical supply terminal board
- Burner on/off switch
- Auxiliary voltage led signal
- Manual or automatic output increase/decrease switch
- Burner working led signal
- Contacts motor and thermal relay with release button
- Motor internal thermal protection
- Motor failure led signal
- Burner failure led signal and lighted release button
- Led signal for correct rotation direction of fan motor
- Emergency button
- Coded connection plugs-sockets
- Burner opening hinge
- Lifting rings
- IP 40 electric protection level.

Conforming to:

- 89/336/EEC directive (electromagnetic compatibility)
- 73/23/EEC directive (low voltage)
- 90/396/EEC directive (gas)
- EN 676 (gas burners).

Standard equipment:

- 1 flange gasket
- 8 screws for fixing the flange
- 1 thermal screen
- 4 screws for fixing the burner flange to the boiler
- Instruction handbook for installation, use and maintenance
- Spare parts catalogue.

Available accessories to be ordered separately:

- DTI module (Data Transfer Interface)
- I/O digital module
- I/O analogic module
- EGA module (Exhaust Gas Analyser) in the following versions:
 - EGA - CO, CO₂, O₂
 - EGA - CO, CO₂, O₂, NO
 - EGA - CO, CO₂, O₂, SO₂
 - EGA - CO, CO₂, O₂, NO, SO₂
- BELDEN 9501 type lead
- Pressure probe 0 - 3 bar
- Pressure probe 0 - 18 bar
- Pressure probe 0 - 30 bar
- Temperature probe 0 - 400°C
- Kit for transformation to LPG
- Burner support
- Adapters
- Stabiliser spring.



RIELLO S.p.A. - Via degli Alpini, 1 - 37045 LEGNAGO (VR) Italy
Tel. ++39.0442630111 - Fax ++39.044221980

Internet: <http://www.rielloburners.com> - E-mail: rburners@rielloburners.com

Since the Company is constantly engaged in the production improvement, the aesthetic and dimensional features, the technical data, the equipment and the accessories can be changed.
This document contains confidential and proprietary information of RIELLO S.p.A.
Unless authorised, this information shall not be divulged, nor duplicated in whole or in part.

